

Your Solution Partner in  
Industrial Valve  
**Automation...**



# Solenoid Valve



## 2/2 & 3/2 Way Solenoid Valve

- High Pressure & High Temperature
- Screwed / Flanged / T. C. End
- Voltage : 12V, 24V, 48V, 110V, 230V, AC/DC
- Coil Type : General / IP 65 & 67 / IS / IEC 60529
- Flame Proof / Weather Proof / Terminal Junction Box
- Intrinsically Safe Coil



Mfg. & Mkt by :

**airaEuroautomation pvt. ltd.**  
INDIA



IBR

CE



[www.airaindia.com](http://www.airaindia.com)



## About Us

*Clients are why we exist!*

We welcome and thank you for referring out detailed catalogue.

**aira** is know all over continents as a manufacturer of quality products - Ball Valves, Butterfly Valves, Plug Valves, & Control On / Off Valves with Pneumatic Actuators for Pharma, Oil & Gas, Steel, Paper, Water, Chemical and all type of processing industries.

**aira** has walked through more than 3 decades, gaining valuable experience, offering equipment's in the products manufactured by OEMs in all spheres of engineering. **aira** products have gained reputations of consultants, and approvals of users, OEMs and other as a quality product.

**aira** has expanding business into foreign markets specially GCC, UAE, Asian & African countries. This is because increase its customer base and revenue, leading to overall growth and success. Now foreign users come to know and believe in the services provided by the **aira**. Along with the same, it also helps to reach a large number of users thereby leading to the increase their business.

Being and ISO 9001 BVQI certified company has put **aira** in fore front. Out motto is "Value the customer" and "Superior product", one among the best in the world.

### Our Quality

- In- House full scale testing facility.
- Lean manufacturing practices
- Certified by : ISO 9001 : 2015 (BVQI LONDON), CE, ATEX, CIMFR, BIS, PESO, SIL 3, IBR
- API 609, API 6D

### Our Commitment

- To understand customer's need first before proposing our products.
- To keep on providing competitive rate's by adapting to continuous process improvement, without compromising on quality.
- To provide continuous support to our customers and go beyond their expectations in terms of delivery and after sale services.

### Our Manufacturing Facility

- In house R & D, manufacturing and testing facility is all located in a spread over three campuses at Ahmedabad, Gujarat, INDIA.

### Network - Sales Office

- 60 Plus Branch Offices in different states in India.
- Sales office in the Bangladesh, Dubai, Kenya, Malaysia, Nepal, Qatar, Singapore, South Africa, Sri Lanka, Turkey, USA (Expanding).

[www.airaindia.com](http://www.airaindia.com)



**QMS (Quality Management System)**

ISO 9001 : 2015

**EMS (Environment Management System)**

ISO 14001 : 2015

**OHSAS (Occupational Health & Safety Management System)**

ISO 45001 : 2018

**IBR**  
PISTON VALVE  
GLOBE CONTROL VALVE (CKD/CND)  
DISC CHECK VALVE (DCV)  
PRESSURE REDUCING VALVE (PRV)  
POP TYPE SAFETY VALVE  
BALL VALVE

**Pneumatic Actuator**

CE /  
ATEX /  
EXIDA SIL-3 /  
PROOF OF DESIGN

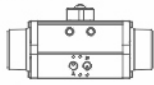

**Scotch & Yoke Actuator**

CE / ATEX / SIL-3

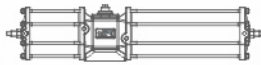

**Stainless Steel Actuator**

CE /  
IEP ATEX



**Positioner Enclosure**

CE / CIMFR /  
IP67 / BIS  
/ PESO

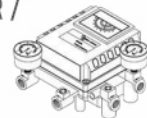

**aira's**  
**SOME OF OUR**  
*Certificates*

**Plug Valve**

FUGITIVE EMISSIONS  
TEST  
AS PER ISO  
15848-1 / IBR



**Flameproof Solenoid Valve**

IEP ATEX / CE / CIMFR  
/ IP65 / IP67 / IP68 /  
BIS / PESO

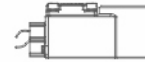

**Limit Switch**

IEP ATEX / CE / CIMFR  
/ IP67 / BIS / PESO /  
EQDC IP68



**Ball Valve (Floating & Trunnion)**

FIRE SAFE TEST DESIGN /  
FUGITIVE EMISSIONS TEST  
AS PER ISO 15848-1 / CE /  
PED / EXIDA SIL-3

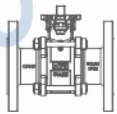

**Butterfly Valve (centric / Double & Triple Eccentric)**

FIRE SAFE TEST DESIGN /  
FUGITIVE EMISSIONS TEST  
AS PER ISO 15848-1 / CE /  
PED / EXIDA SIL-3  
IBR / PROOF OF DESIGN /  
FOOD GRADE / BIS / ISI



**Multiport Ball Valve**

FUGITIVE EMISSIONS TEST  
AS PER ISO 15848-1 / CE /  
PED / EIL

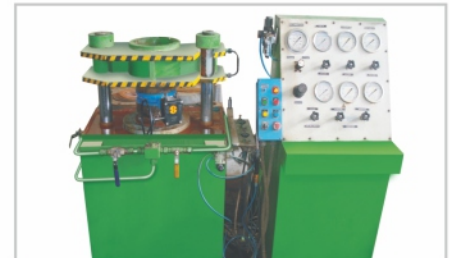
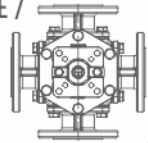

# Company Profile



[www.airaindia.com](http://www.airaindia.com)



# 2/2 Way Semi Lift Diaphragm Operated Low Pressure Solenoid Valve



Model : GTD

"aira" Offers 2/2 way semi Lift, high performance diaphragm type solenoid Valves, for high volume and low pressure application in air, gas, water, vacuum, light oil, corrosive fluids. available in normally close and normally open design.

## Size Range : 3/8" to 4" Screwed / Flanged / Triclover End

| Valves Specification |   |
|----------------------|---|
| Pressure Rating      | 0 to 5 Bar Max. ( 0 to 6 Bar On Request )   |
| Temperature of Fluid | 180 OC Max. ( High Temperature On Request )   |
| Coil Voltage         | 12V, 24V, 48V, 110V, 230V, AC/DC  |
| Coil Insulation      | "F" & "H" Class Suitable Upto 180 OC  |
| Coil Encloser Meets  | IP 67 ( Flame Proof / Explosion Proof as Per IS / IEC 60079-1 STD for Gas Group II C Zone 1 & 2 |
| Coil Ratings         | Continuous Rated  |
| Ends                 | Screwed / Flanged 150# / TC End   |

### Suitable For

Autoclaves, Gas burning equipments, Oil centrifuge plants, Vacuum plants, Pump seal water application, Low pressure water circulation system, solar heating systems, Gas generator etc...

### Technical Specification Table

| Valve Size | Orifice | Flow Factor | Min. Pressure        | Maximum Operating Pressure ( Bar ) |           |       |           |           |       |           |
|------------|---------|-------------|----------------------|------------------------------------|-----------|-------|-----------|-----------|-------|-----------|
|            |         |             |                      | AC                                 |           |       | DC        |           |       |           |
| MM         | Inch    | MM          | Kvm <sup>3</sup> /hr | Bar                                | Air / Gas | Water | Light Oil | Air / Gas | Water | Light Oil |
| 10         | 3/8"    | 17          | 2.6                  | 0                                  | 6         | 4.0   | 3.0       | 6         | 5.0   | 3.0       |
| 15         | 1/2"    | 17          | 3.4                  | 0                                  | 6         | 4.0   | 3.0       | 6         | 5.0   | 3.0       |
| 20         | 3/4"    | 20          | 4.3                  | 0                                  | 6         | 3.5   | 3.0       | 6         | 4.0   | 3.0       |
| 25         | 1"      | 25.5        | 10.3                 | 0                                  | 6         | 3.5   | 2.0       | 6         | 4.0   | 2.5       |
| 40         | 1.1/2"  | 38          | 19.3                 | 0                                  | 5         | 3     | 2.0       | 5         | 4.0   | 2.0       |
| 50         | 2"      | 47.5        | 32.5                 | 0                                  | 4         | 3     | 2.0       | 4         | 3.0   | 2.0       |

### Solenoid Coil



Weatherproof Coil



Explosion & Flame Proof Coil [As per IS / IEC 60079-1 standard approved by Central Institute of Mining and Fuel Research (CIMFR)]

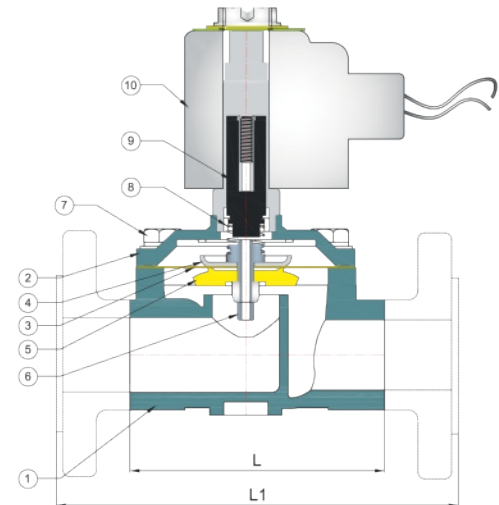
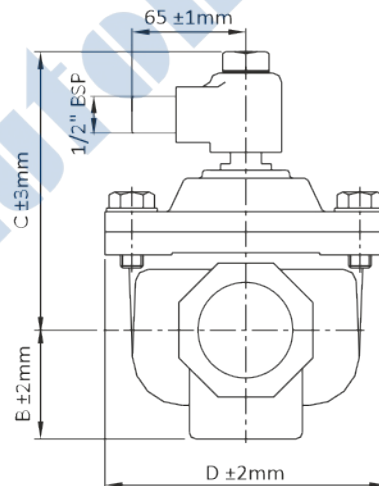

### Dimensions :

| Valve Model | Valve Size |        | L S / E | L1 F / E | B  | C     | D     | Weight Approx. |        |
|-------------|------------|--------|---------|----------|----|-------|-------|----------------|--------|
|             | MM         | Inch   |         |          |    |       |       | S / E          | F / E  |
| GTD - 10    | 10         | 3/8"   | 65.5    | 130      | 16 | 112   | 57    | 1.050          | 1.500  |
| GTD - 15    | 15         | 1/2"   | 65.5    | 130      | 16 | 112   | 57    | 1.000          | 1.400  |
| GTD - 20    | 20         | 3/4"   | 80      | 150      | 21 | 113   | 67    | 1.200          | 1.700  |
| GTD - 25    | 25         | 1"     | 97      | 160      | 29 | 121   | 82    | 1.500          | 2.250  |
| GTD - 40    | 40         | 1.1/2" | 119     | 200      | 35 | 132   | 99    | 2.050          | 3.350  |
| GTD - 50    | 50         | 2"     | 137     | 230      | 43 | 146   | 120   | 3.100          | 5.200  |
| GTD - 65    | 65         | 2.1/2" | 172     | 290      | 56 | 166.5 | 143   | 4.600          | 9.400  |
| GTD - 80    | 80         | 3"     | 195     | 310      | 57 | 166   | 185   | 6.550          | 10.050 |
| GTD - 100   | 100        | 4"     | 300     | 350      | 79 | 195   | 215.5 | 13.450         | 18.850 |

Note : Flange Dimensions as per 150#.

(All Dimensions are in mm)

| Sr. No. | Description       | Material          |
|---------|-------------------|-------------------|
| 1       | Body              | CF8 / CF8M / CF3M |
| 2       | Cover             | CF8 / CF8M / CF3M |
| 3       | Diaphragm         | PTFE              |
| 4       | Embossed Washer   | S.S. 304          |
| 5       | Diaphragm Seat    | PTFE              |
| 6       | Pilot Pin + Nut   | S.S. 304          |
| 7       | Hex Bolt + Washer | S.S.              |
| 8       | Taper Spring      | S.S. 304          |
| 9       | Housing Set       | STD.              |
| 10      | Sol. Coil Body    | STD.              |

www.airaindia.com



## Installations

- Indian Oil
- Reliance Industries Limited
- ONGC
- Hindalco
- Godrej
- Indian Railway
- Vedanta
- Voltas
- NTPC
- Gujarat State Fertilizers & Chemical Ltd.
- L & T
- Gail
- Hindustan Petroleum
- BHEL
- IFFCO
- BARC
- Thermax
- Essar

# Applications

- Air
- Water
- Gas
- Light Oil
- Light Chemical
- High Volume & Low Pressure Application
- Vacuum
- Corrosive Fluids
- Autoclaves
- Gas Burning Equipments
- Pump Seal Water Application
- Low Pressure Water Circulation System
- Solar Heating System
- Gas Generator
- Hot Water
- Steam
- High Temperature Fluids
- LD Oil
- Chemical
- Dust Collector Application
- Ceramic Filters
- Drain & Dispensing
- Oil Centrifuge Plants
- Low Pressure Oil

This Product is Generally made to use on the High Pressure Piping System, It is Widely Applied for Major Industrial Sectors

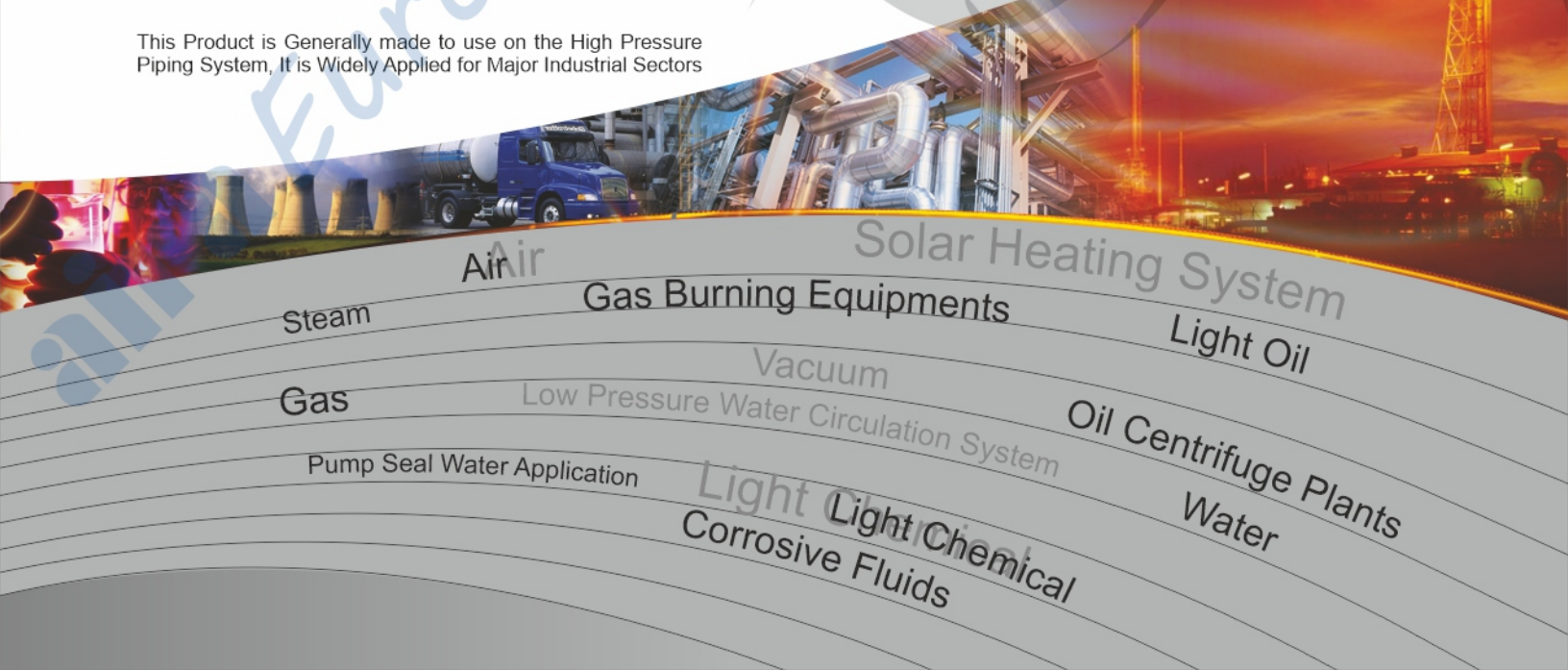

Air  
Solar Heating System  
Gas Burning Equipments  
Light Oil  
Steam  
Vacuum  
Oil Centrifuge Plants  
Gas  
Low Pressure Water Circulation System  
Water  
Pump Seal Water Application  
Light Chemical  
Corrosive Fluids



*time tested designs with superior performance*

# GLOBAL

Network

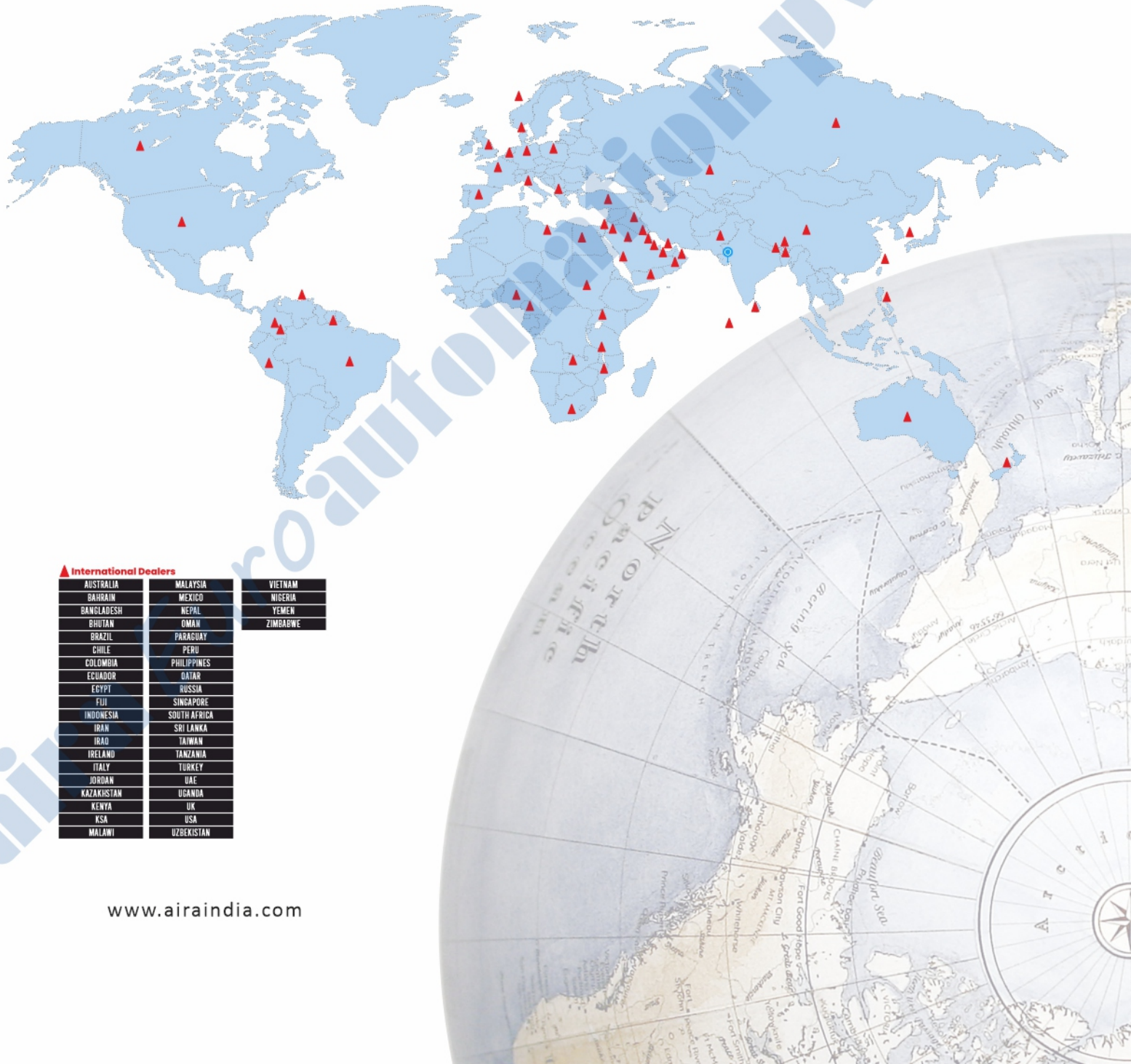

**▲ International Dealers**

|             |              |          |
|-------------|--------------|----------|
| AUSTRALIA   | MALAYSIA     | VIETNAM  |
| BAHRAIN     | MEXICO       | NIGERIA  |
| BANGLADESH  | NEPAL        | YEMEN    |
| BHUTAN      | OMAN         | ZIMBABWE |
| BRAZIL      | PARAGUAY     |          |
| CHILE       | PERU         |          |
| COLOMBIA    | PHILIPPINES  |          |
| ECUADOR     | QATAR        |          |
| EGYPT       | RUSSIA       |          |
| FUJI        | SINGAPORE    |          |
| INDONESIA   | SOUTH AFRICA |          |
| IRAN        | SRI LANKA    |          |
| IRAQ        | TAIWAN       |          |
| IRELAND     | TANZANIA     |          |
| ITALY       | TURKEY       |          |
| JORDAN      | UAE          |          |
| KAZAKHISTAN | UGANDA       |          |
| KENYA       | UK           |          |
| KSA         | USA          |          |
| MALAWI      | UZBEKISTAN   |          |



*industrial valve automation*

# Network

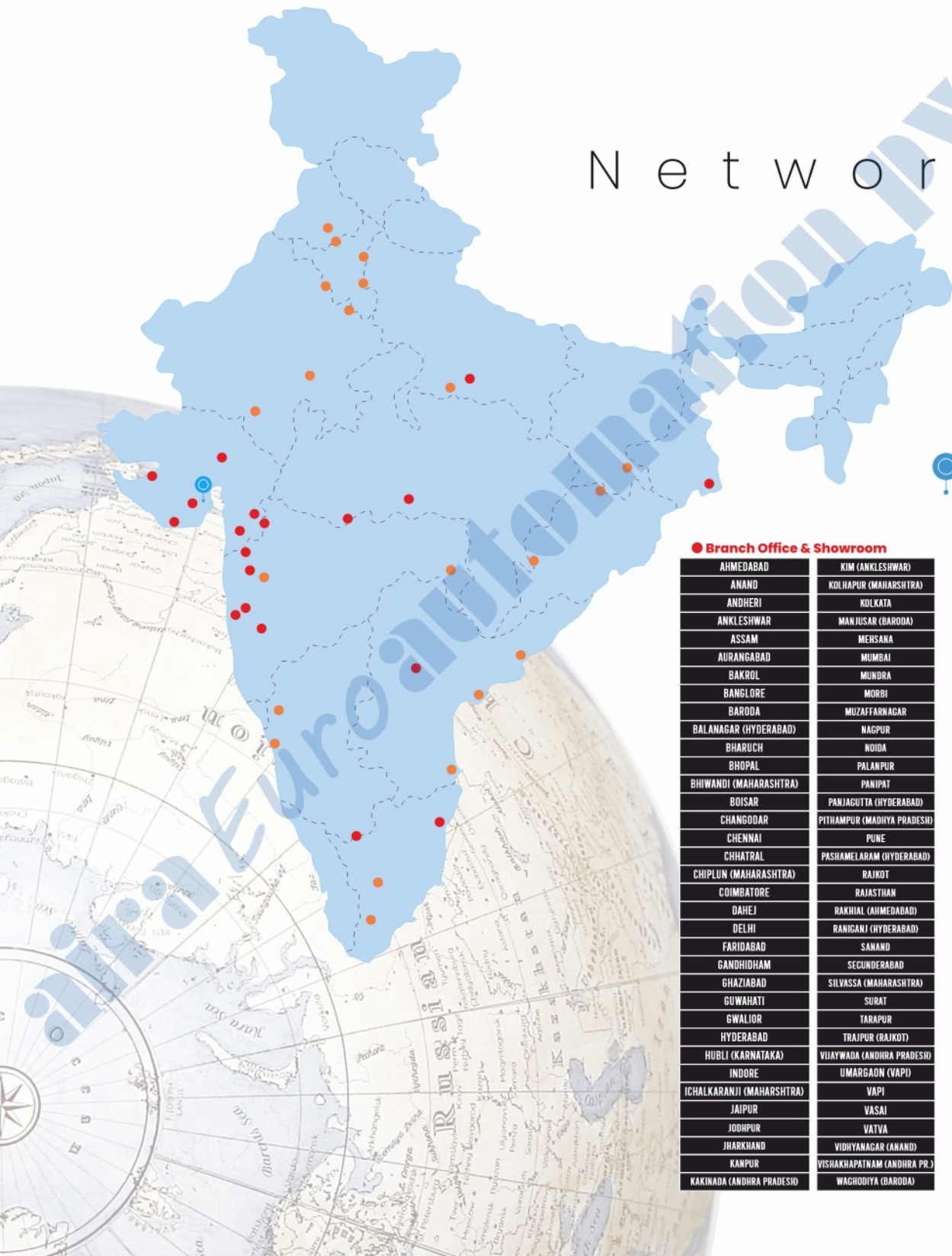

● Head Office & Works  
AHMEDABAD

● Branch Office & Showroom

|                            |                             |
|----------------------------|-----------------------------|
| AHMEDABAD                  | KIM (ANKLESHWAR)            |
| ANAND                      | KOLHAPUR (MAHARASHTRA)      |
| ANDHERI                    | KOLKATA                     |
| ANKLESHWAR                 | MANJUSAR (BARODA)           |
| ASSAM                      | MEHSANA                     |
| AURANGABAD                 | MUMBAI                      |
| BAKROL                     | MUNDRA                      |
| BANGLORE                   | MORBI                       |
| BARODA                     | MUZAFFARNAGAR               |
| BALANAGAR (HYDERABAD)      | NAGPUR                      |
| BHARUCH                    | NOIDA                       |
| BHOPAL                     | PALANPUR                    |
| BHIWANDI (MAHARASHTRA)     | PANIPAT                     |
| BOISAR                     | PANJAGUTA (HYDERABAD)       |
| CHANGODAR                  | PITHAMPUR (MADHYA PRADESH)  |
| CHENNAI                    | PUNE                        |
| CHHATRAL                   | PASHAMELARAM (HYDERABAD)    |
| CHIPLUN (MAHARASHTRA)      | RAJKOT                      |
| COIMBATORE                 | RAJASTHAN                   |
| DAHEJ                      | RAKHIAL (AHMEDABAD)         |
| DELHI                      | RANIGANJ (HYDERABAD)        |
| FARIDABAD                  | SANAND                      |
| GANDHIDHAM                 | SECUNDERABAD                |
| GHAZIABAD                  | SILVASSA (MAHARASHTRA)      |
| GUWAHATI                   | SURAT                       |
| GWALIOR                    | TARAPUR                     |
| HYDERABAD                  | TRAJIPUR (RAJKOT)           |
| HUBLI (KARNATAKA)          | VIJAYWADA (ANDHRA PRADESH)  |
| INDORE                     | UMARGAON (VAPI)             |
| ICHALKARANJI (MAHARASHTRA) | VAPI                        |
| JAIPUR                     | VASAI                       |
| JODHPUR                    | VATVA                       |
| JHARKHAND                  | VIDHYANAGAR (ANAND)         |
| KANPUR                     | VISHAKHAPATNAM (ANDHRA PR.) |
| KAKINADA (ANDHRA PRADESH)  | WAGHODIYA (BARODA)          |

● Dealers & Distributors

|            |               |
|------------|---------------|
| AMRITSAR   | KOLKATA       |
| BALOTA     | LUCKNOW       |
| BANGLORE   | LUDHIANA      |
| BELGAUM    | MARWAR        |
| BHILWARA   | MEERUT        |
| CHANDICARH | MUZAFFARNAGAR |
| CHENNAI    | NAGPUR        |
| COCHIN     | NOIDA         |
| COIMBATORE | PANIPAT       |
| DELHI      | PEENYA        |
| ERODE      | PUNE          |
| FARIDABAD  | TRIPUR        |
| GHAZIABAD  | VARANASI      |
| GOA        | VISAKHAPATNAM |
| INDORE     | WADI          |
| JALANDHAR  | KANPUR        |
| JAMSHEDPUR | KOLHAPUR      |
| JHARKHAND  |               |





aira Euroautomation

Mfg. & Mkt by :

**aira Euroautomation pvt. ltd.**

**INDIA**

Available At :



[www.airaindia.com](http://www.airaindia.com)